

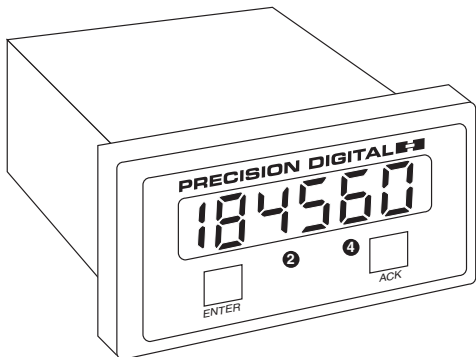

# DIGITAL PANEL METERS

## Model PD694 Universal VDC Input Meter Instruction Manual



- Easy **S**ingle **B**utton **S**caling (**SBS**)
- 0-200 VDC Input
- 24 V Transmitter Power Supply Standard
- Steady, Accurate Display from -199,990 to 299,990
- 4½ Digit + Extra Zero
- Type 4X, NEMA 4X Front Panel
- 2 or 4 Relays + 4-20 mA Output Options
- Green Display Available
- Lockout Feature
- Non-Volatile Memory, No Battery Needed
-  US Listed ( AC Powered Units Only)

**PRECISION DIGITAL CORPORATION**  
19 Strathmore Road • Natick MA 01760 USA  
Tel (800)-343-1001 • Fax (508)-655-8990

**PRECISION  
DIGITAL**   
[www.predig.com](http://www.predig.com)

|   |    |
|---|----|
| <b>INTRODUCTION</b> .....   | 4  |
| <b>Ordering Information</b> .....                                       | 4  |
| <b>Safety Notice</b> .....  | 5  |
| <b>Specifications</b> .....   | 6  |
| Basic Meter.....  | 6  |
| Options .....   | 7  |
| <b>Display Messages and Functions</b> .....                             | 9  |
| <b>SETUP AND PROGRAMMING</b> .....                                      | 10 |
| <b>Power, Signal, External Functions &amp; Options Connections</b> ..   | 10 |
| Overview .....  | 11 |
| Wiring Instructions.....  | 11 |
| AC Powered Units (Power, Signal, External Functions) .....              | 12 |
| Relays & 4-20 mA Output .....   | 13 |
| 4-20 mA Output .....  | 14 |
| <b>Programming</b> .....  | 15 |
| Overview.....   | 15 |
| Single Button Scaling (SBS) .....                                       | 15 |
| Two-point External Calibration Flow Chart .....                         | 16 |
| Five Basic Digit/Display-setting Instructions .....                     | 17 |
| General Calibration Instructions .....                                  | 18 |
| Calibration Error ( <i>Error</i> ) .....                                | 18 |
| Programming Confirmation .....  | 18 |
| <b>Isolated 4-20 mA Output Option Programming (<i>outPut</i>)</b> ..... | 19 |
| Setting 4 mA Output Value.....  | 19 |
| Setting 20 mA Output Value.....   | 19 |
| Programming Confirmation .....  | 19 |
| <b>Alarm Programming</b> .....  | 20 |
| Overview .....  | 20 |
| Setting Alarm Set & Reset Points ( <i>RLR5</i> ) .....                  | 20 |
| Programming Confirmation .....  | 21 |
| Alarm Operation.....  | 21 |
| Set Relays for Fail-Safe Operation .....                                | 21 |
| Alarm Acknowledgment .....  | 22 |
| Latching (L) or Automatic (R) Relays.....                               | 22 |

|  |    |
|--|----|
| Lockout Jumper .....                               | 23 |
| <b>SWITCHING INDUCTIVE LOADS</b> .....             | 24 |
| AC & DC Loads.....                                 | 24 |
| Low Voltage DC Loads.....                          | 24 |
| RC Networks Available from Precision Digital ..... | 24 |
| <b>OPTION CARD INSTALLATION</b> .....              | 25 |
| <b>MOUNTING DIMENSIONS</b> .....                   | 26 |
| <b>OTHER PRECISION DIGITAL PRODUCTS</b> .....      | 27 |
| <b>HOW TO CONTACT PRECISION DIGITAL</b> .....      | 28 |

## INTRODUCTION

The PD694 DC Volt Meter accepts 0-200 VDC and displays this signal in engineering units on a 4 1/2 digit display. The display also includes an extra zero which may be used to handle numbers up to 299,990.

### Ordering Information

| 115 VAC Model | 230 VAC Model | 24 VDC Model | Description               | Option Card* |
|---------------|---------------|--------------|---------------------------|--------------|
| PD694-3-N     | PD694-4-N     | PD694-2-N    | No Options                |              |
| PD694-3-14    | PD694-4-14    | PD694-2-14   | 2 Relays                  | PD174        |
| PD694-3-15    | PD694-4-15    | PD694-2-15   | 4-20mA Out                | PD175        |
| PD694-3-16    | PD694-4-16    | PD694-2-16   | 2 Relays +<br>4-20 mA Out | PD176        |
| PD694-3-17    | PD694-4-17    | PD694-2-17   | 4 Relays                  | PD177        |
| PD694-3-18    | PD694-4-18    | PD694-2-18   | 4 Relays +<br>4-20 mA Out | PD178        |

Add (-G) to part number to call out meters with green display:

Example: PD694-3G-14

\*Part numbers for Option Cards when purchased separately

## Safety Notice



**CAUTION:** Read complete instructions prior to installation and operation of the Meter.



**WARNING:** Risk of electric shock.



Observe all safety regulations. Electrical wiring should be performed in accordance with all applicable national, state and local codes to prevent damage to the Meter and ensure personnel safety.

Do not use this meter to directly drive heavy equipment such as pumps, motors, valves, etc.



It is recommended to use this meter in a fail-safe system that accommodates the possibility of meter failure or power failure.



### **WARNING**

***Hazardous voltages exist within enclosure. Installation and service should be performed only by trained service personnel.***



### **AVERTISSEMENT**

***Les pièces à l'intérieur du boîtier portent des tensions dangereuses. Seules des personnes qualifiées et bien entraînées devraient entreprendre l'ótalonnage et la maintenance.***

## **DISCLAIMER**

The information contained in this document is subject to change without notice. Precision Digital makes no representations or warranties with respect to the contents hereof, and specifically disclaims any implied warranties of merchantability or fitness for a particular purpose.

## SPECIFICATIONS

Except where noted all specifications apply to operation at +25°C

### Basic Meter

|                                |  |
|--------------------------------|--|
| <b>INPUT</b>                   | 0-200 VDC  |
| <b>DISPLAY</b>                 | Bright, large, 0.56" (14.2mm) high efficiency red or green LEDs. 4 1/2 digits + extra zero may be switched on to display from -19999(0) to 29999(0). Leading zeros blanked.                        |
| <b>DECIMAL POINT</b>           | Decimal point may be placed in any of the following positions. 1.9999, 19.999, 199.99, 1999.9, 19999 or 199990 with extra zero.  |
| <b>CALIBRATION RANGE</b>       | 0 VDC input may be set anywhere in range of the meter. 200 VDC may be set anywhere above or below 0 VDC input. An <i>Error</i> message will appear if input 1 and input 2 signal are within 5 VDC. |
| <b>INPUT IMPEDANCE</b>         | Greater than 1 M $\Omega$  |
| <b>LOOP POWER</b>              | (AC Meters only), Isolated 24 VDC $\pm$ 5% @ 20 mA regulated. Maximum loop resistance is 1200 $\Omega$ .   |
| <b>HOLD READING</b>            | Connect terminals H and CM   |
| <b>ACCURACY</b>                | $\pm$ 0.05% of calibrated span, $\pm$ 1 count.   |
| <b>ALARM POINTS</b>            | Four, any combination of high or low alarms.   |
| <b>ALARM POINT DEADBAND</b>    | 0-100% of full scale, user selectable.   |
| <b>ALARM STATUS INDICATION</b> | Front panel LED.   |
| <b>LOCKOUT</b>                 | Jumper J3 restricts modification of calibration values.  |
| <b>NON-VOLATILE MEMORY</b>     | All programming values are stored in non-volatile memory for a minimum of ten years if power is lost. No battery needed.   |
| <b>NORMAL MODE REJECTION</b>   | 64 dB at 50/60 Hz.   |

|                          |  |
|--------------------------|--|
| <b>POWER</b>             | AC power, 115 or 230 VAC $\pm 10\%$ , 50/60 Hz, 10 VA.<br>DC Power, 18-36 VDC; 6 watts maximum.  |
| <b>ISOLATION</b>         | AC power: 1500 VAC;<br>DC power: 500 VDC.  |
| <b>ENCLOSURE</b>         | 1/8 DIN, High Impact plastic, UL 94V-0   |
| <b>FRONT PANEL</b>       | Type 4X, NEMA 4X, Panel Gasket provided  |
| <b>ENVIRONMENTAL</b>     | Operational ambient temperature range: 0 to +60°C. Storage temperature range: -40 to +85°C. Relative humidity: 0 to 90% non-condensing.  |
| <b>CONNECTIONS</b>       | Removable screw terminal blocks (provided) accept 22 to 12 AWG wire.   |
| <b>WARRANTY</b>          | 1 year parts & labor.  |
| <b>EXTENDED WARRANTY</b> | Warranty may be extended an additional 12 months by returning the Product Registration Form within 2 months from date of purchase. Go to <a href="http://www.predig.com">www.predig.com</a> for online registration. |
| <b>UL FILE NUMBER</b>    | E160849; 508 Industrial Control Equipment (AC powered units only)  |

## Options

### Relays

|                          |   |
|--------------------------|---|
| <b>RATING</b>            | 2 or 4 SPDT (form C); rated 2 Amp @ 30 VDC or 2 Amp @ 250 VAC resistive load; 1/14 HP @ 125 / 250 VAC for inductive loads.  |
| <b>RESET</b>             | User Select: <ol style="list-style-type: none"> <li>1. Automatically when input passes reset point.</li> <li>2. Automatically + Manually (via user supplied switch or front panel ACK button). Manual reset resets all manually resettable relays.</li> <li>3. Manually at any time.</li> <li>4. Manually only after alarm condition has been corrected.</li> </ol> |
| <b>DEADBAND</b>          | 0-100% of full scale, user selectable.  |
| <b>HIGH OR LOW ALARM</b> | User may program any alarm for a high or low trip point.  |

**FAIL-SAFE OPERATION** Relay coils are energized in non-alarm condition. In case of power failure, relays will go to alarm state. Fail-Safe operation may be disabled, by removing jumper J2 located on the Options PCB.

**AUTO INITIALIZATION** When power is applied to the meter, relays will always reflect the state of the input to the meter.

### Isolated 4-20 mA Transmitter Output

**CALIBRATION RANGE** The transmitter output can be calibrated so that a 4 mA output is produced for any number displayed by the meter. The 20 mA output may correspond to any number that is at least 501 counts greater or smaller than the number corresponding to 4 mA. (Ex. 4 mA = 0, 20 mA = 501) If the span between 4 and 20 mA is less than 501 counts, an error message will appear.

**EQUIPMENT NEEDED** The 4-20 mA output is calibrated without the use of a calibrator. No equipment needed.

**OUTPUT LOOP-POWER** (AC powered meters only), Isolated 24 VDC  $\pm$  5% @ 20mA regulated. Maximum loop resistance is 1200  $\Omega$ . Available for either signal input or 4-20 mA output, but not both.

**ACCURACY**  $\pm$  0.1% F.S.,  $\pm$  0.004 mA.

**ISOLATION** 500 VDC or peak AC, input-to-output or input/output-to-power line.

**EXTERNAL LOOP-POWER SUPPLY** 35 VDC max.

| <b>OUTPUT LOOP RESISTANCE</b> | <b>Power supply</b> | <b>Min. loop resistance</b> | <b>Max loop resistance</b> |
|-------------------------------|---------------------|-----------------------------|----------------------------|
|                               | 24 VDC              | 10 $\Omega$                 | 600 $\Omega$               |
|                               | 35 VDC (external)   | 600 $\Omega$                | 1000 $\Omega$              |



## Display Messages and Functions

The following table describes the various messages displayed by the meter during programming and operation:

| <b>Display</b> | <b>Parameter</b>             | <b>Description/Comments</b>                                  |
|----------------|------------------------------|--|
| <i>CAL Ib</i>  | Perform External Calibration | Calibrate meter using an external calibration source.        |
| <i>INPt 1</i>  | Input 1                      | Set Input 1 calibration value.                               |
| <i>INPt 2</i>  | Input 2                      | Set Input 2 calibration value.                               |
| <i>DECPt</i>   | Decimal Point                | Set decimal point or light up extra "0".                     |
| <i>ALARMS</i>  | Alarms                       | Program alarm/relay set and reset points.                    |
| <i>OUTPut</i>  | Output                       | Set 4-20 mA output values.                                   |
| <i>19999</i>   | Overrange                    | Indicates input signal exceeds full-scale range of meter.    |
| <i>- 19999</i> | Underrange                   | Indicates input signal is below the negative range of meter. |
| <i>Error</i>   | Error                        | Indicates calibration was not successful.                    |

## SETUP AND PROGRAMMING

### Power, Signal, External Functions & Options Connections



Disconnect power to the meter before making any connections.



Do not connect power or earth ground to any unused or CM terminals.



Observe polarity for DC powered Meters. Applying voltage with reverse polarity may damage the instrument.



Connecting 230 VAC to a meter specified to accept 115 VAC or connecting AC power to a meter specified to accept DC power will result in damage to the instrument as well as endanger personnel. Keep primary wires separated from signal cables.

#### Notice:

- Primary voltages must not be accessible to the user.
- Primary wires must be installed in accordance to the applicable standards.

### Terminals Designation

| Terminal | Description                |
|----------|----------------------------|
| L, L     | AC input power             |
| V+, V-   | DC input power             |
| P+, P-   | 24 VDC output power        |
| S+, S-   | Input signal               |
| AK       | External relay acknowledge |

| Terminal | Description                  |
|----------|------------------------------|
| H        | Hold reading                 |
| CM       | Common (return) for AK and H |
| +, -     | 4-20 mA output               |
| 1-6      | Relay 1-4                    |

## Overview

The following field wiring connections are made to removable screw terminal blocks supplied with the meter:

Power, Signal Input, Acknowledge and Hold

Options: Relays & 4-20 mA Output

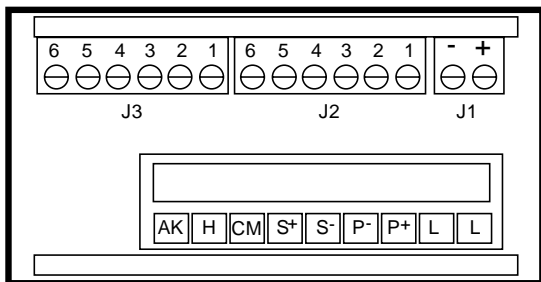
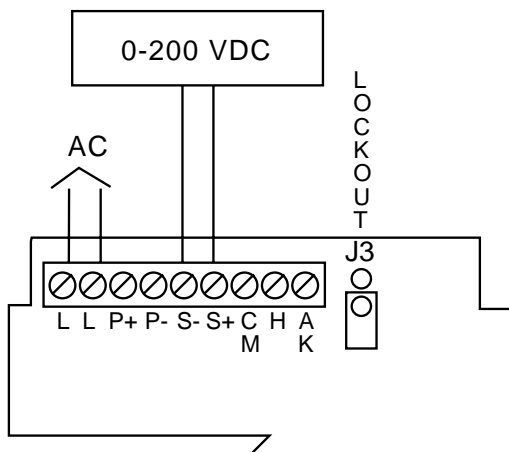
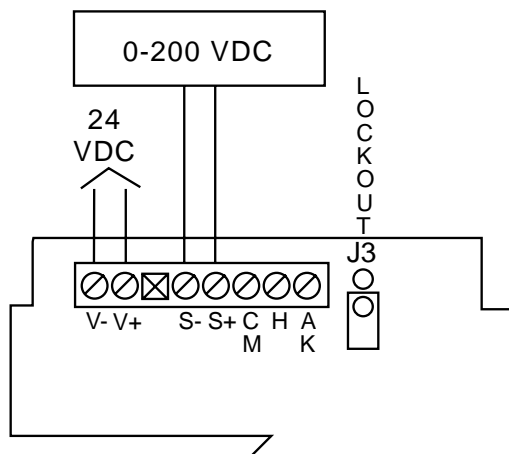

**Figure 1: Rear View of Meter (Connectors)**

| Label | Main PCB (Lower)             | Wire Size |
|-------|------------------------------|-----------|
| None  | Power                        | 12-18     |
| None  | Signal, Acknowledge, Hold    | 12-22     |
|       | <b>Options PCB (Upper)</b>   |           |
| J1    | 4-20 mA Output               | 12-22     |
| J2    | Relays 1 & 2; NC, NO, Common | 12-22     |
| J3    | Relays 3 & 4; NC, NO, Common | 12-22     |

## Wiring Instructions

- All field connections to be made with insulated copper wire, either solid or stranded. Tighten all screw terminals to 4.5 lb-in (0.5 Nm). Strip length = 1/4 in (7mm). **DO NOT** pre-treat wire with solder.
- Terminals L & L:** Use AWG #12-18 wire, 600 volt, 60°C. Connect only one wire to each terminal on the 9-pin connector.
- Terminals AK, H, CM, S+, S-, P-, P+:** Use AWG #12-22 wire, 150 volt, 60°C. If using AWG #20 or smaller wire, up to 2 wires may be connected to each terminal. If using AWG #18 or larger wire, only one wire may be connected to each terminal.

**AC Powered Meters (Power, Signal, External Functions)****Figure 2: AC Powered Units****Figure 3: DC Powered Units**

## Relays & 4-20 mA Output

Depending on the model number, the Options PCB may contain two or four relays and an Isolated 4-20 mA Transmitter Output. Relay connections are made to removable screw terminal connectors located at J2 and J3 on the Options PCB. Connections for the Isolated 4-20 mA Transmitter Output are made to J1 on the Options PCB.

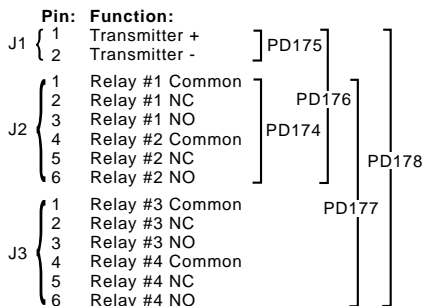

**Figure 4: Option Card Pinouts**

Notes:

1. Alarm acknowledgement terminals (ACK and COM) are located on the meter main board.
2. In the alarm condition, the NC contact is connected to common in the fail safe mode.

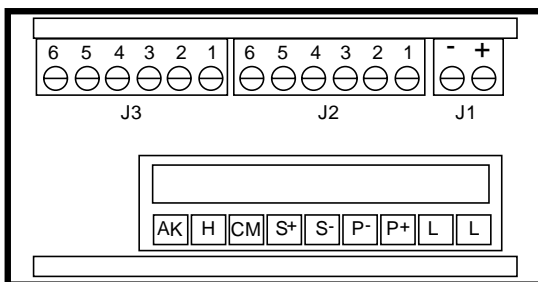

**Figure 5: Rear View of Meter (Connectors)**

## 4-20 mA Output

The 4-20 mA output from the meter can either be powered from the meter's internal transmitter power supply, or by an external power supply as the following diagrams illustrate:

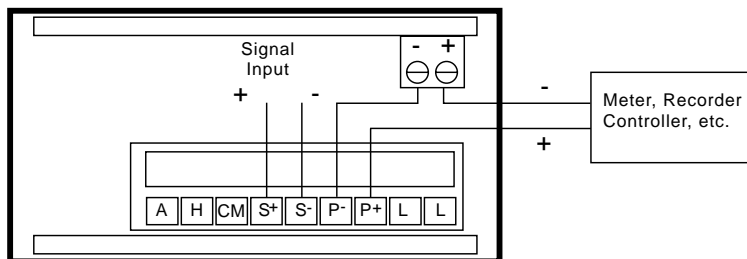

**Figure 6: Meter Powering 4-20 mA Output Loop**

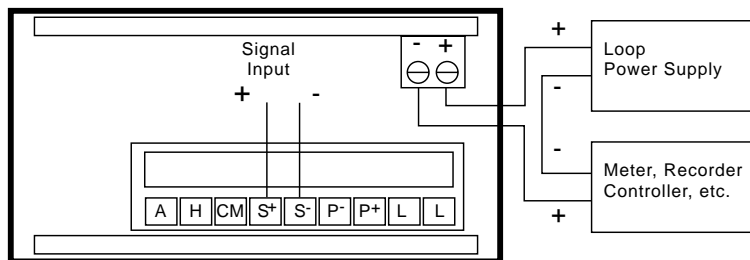

**Figure 7: External Power Supply Powering 4-20 mA Output Loop**



If the output loop is powered by an external supply, the loop power supply must be turned on before the meter is turned on. Otherwise, the output loop signal may be incorrect.

## Programming

### Overview

The meter is programmed using the **ENTER** button and three jumper arrays. The **ENTER** button controls the meter's **Single Button Scaling (SBS)** feature that allows the meter to be completely programmed using just one button. The jumper arrays are used for programming the input signal, lockout, relays acknowledge enable and relays Fail-Safe operation.

### Single Button Scaling (SBS)

**Single Button Scaling** is a technique that allows the meter to be completely programmed using just the **ENTER** button. The general method behind (**SBS**) is to push **ENTER** when the meter reads the desired value. This value may be a menu title, the entire display or just a single digit. If the meter is not reading the desired value wait and the value will change. When the meter finally reads the desired display push **ENTER** to accept it.

When the meter is first powered up, it will read a random number. Pushing **ENTER** will cause the meter to scroll through the following menu titles (if the Lockout Jumper is not installed):

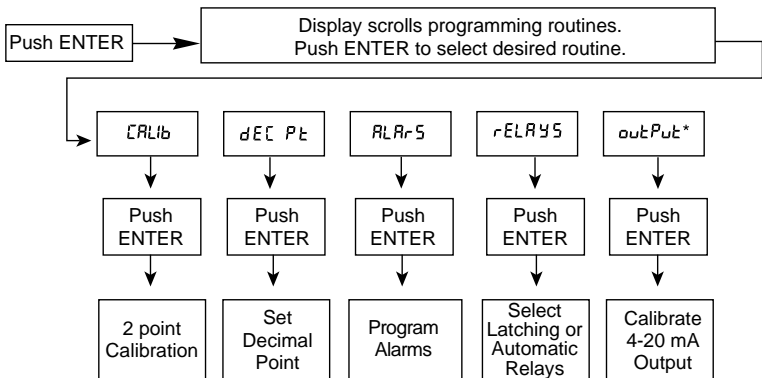

\* Only appears if this option is installed

**Figure 8: Menu Scroll (with Lockout Jumper Removed)**

**Figure 9: Two-point External Calibration Flow Chart**

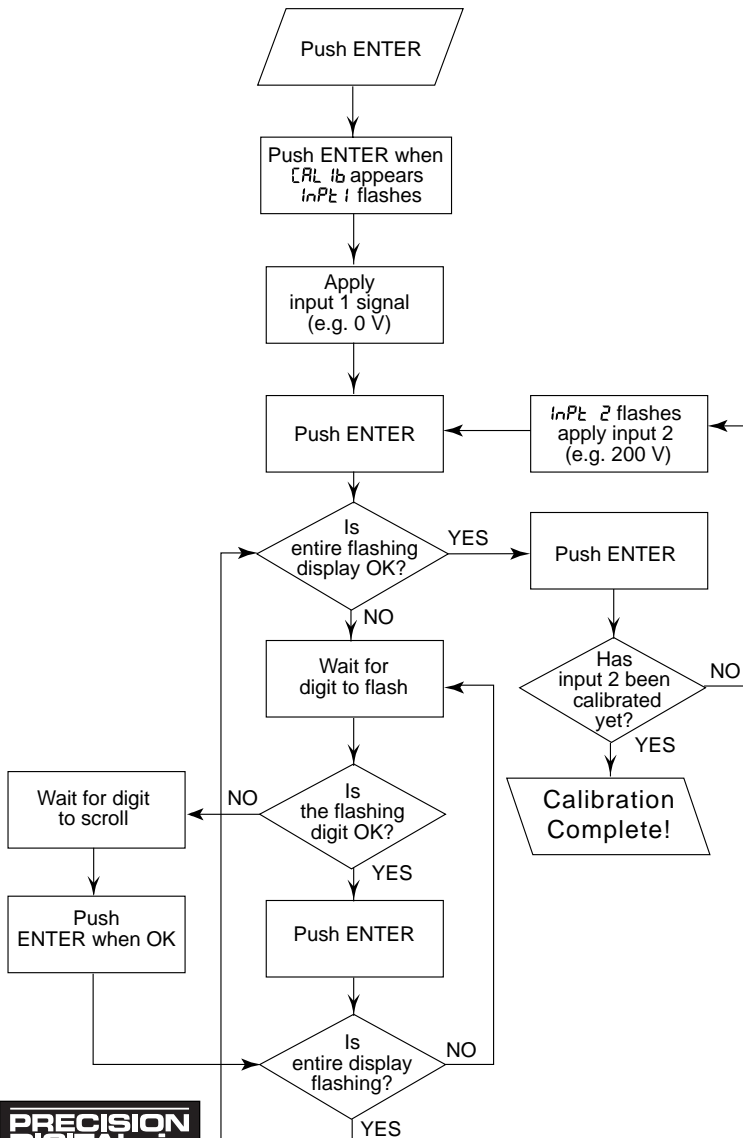



## Five Basic Digit/Display-setting Instructions

Rather than repeat the **Single Button Scaling (SBS)** technique for every function it is used in, it will be detailed here and the user can refer to it when necessary.

The **Single Button Scaling** technique is used to program all the meter's functions that require numbers to be entered. For instance, calibration, alarm set and reset points, 4 and 20 mA output values are set using **(SBS)**.

1. If the flashing display is OK, push **ENTER** before it stops flashing to accept it. (Whenever a new value is to be programmed or last digit has been accepted the entire display flashes, if this is the desired value, press **ENTER** before it stops flashing to accept it.)
2. If the flashing display is not OK, (or if **ENTER** was not pushed in time to accept it), wait for first digit to flash.
3. If a flashing digit is OK, push **ENTER** before it starts to scroll to accept it.
4. If a flashing digit is not OK, (or if **ENTER** was not pushed in time to accept it), wait for the digit to scroll and push **ENTER** when OK.
5. Digits will scroll until **ENTER** is pushed. When a digit is accepted by pushing **ENTER**, the next digit to the left flashes.

## General Calibration Instructions

Calibration is performed from the front panel using the **ENTER** button. It does not require any tools or disassembly of the meter. The only equipment needed is a calibrated signal source.

### Select Decimal Point (*dECPt*)

To program the decimal point or light up the extra "0", push **ENTER**. The meter displays *CRt Ib*, then *dECPt*. Push **ENTER** when *dECPt* appears. The meter then reads 199990 with the decimal point changing locations and the extra "0" illuminating. Push **ENTER** when the decimal point is in the desired position; or if the extra "0" is desired; when the extra "0" is displayed.

**For best results, allow meter to warm up for at least 30 minutes.**

The calibration input signals must be within the range of the meter and input 2 must be greater than input 1. (However, display for input 2 does not have to be greater than desired display for input 1.)

An *Error* message will appear if input 1 signal and input 2 signal are within 5 VDC of each other.

1. Push **ENTER**, when *CRt Ib* appears push **ENTER** again.
2. *inp1 1* flashes. Apply input 1 signal (e.g. 0 VDC) then push **ENTER**, Program desired display for input 1.
3. *inp1 2* flashes. Apply input 2 signal (e.g. 200 VDC) then push **ENTER**. Program desired display for input 2.

### Calibration Error (*Error*)

A meter display of *Error* during calibration indicates that the calibration process was not successful and the meter needs to be recalibrated.

1. The *Error* message will appear if input 1 signal and input 2 signal are within 5 VDC of each other.
2. The *Error* message will appear if input 1 signal is inadvertently also applied for input 2 calibration, or **ENTER** is pushed before applying input 2.

### Programming Confirmation

The values that have been programmed can be quickly checked to make sure they are the desired values. To do this, apply the desired signal for each point and check the display.

### Isolated 4-20 mA Transmitter Output Programming (*outPut*)

The Isolated 4-20 mA Transmitter Output option can be programmed without a calibrator. This option can be calibrated so that a 4 mA output is produced for any number displayed by the meter. The 20 mA output may be programmed to correspond to any number that is at least 501 counts greater or smaller than the number corresponding to 4 mA. (Ex. 4 mA = 0, 20 mA = 501 or -501) If the span between 4 and 20 mA is less than 501 counts, an *Error* message will appear and the previously programmed values will be retained in memory until a new set of values is accepted.

#### Setting 4 mA Output Value

1. Push **ENTER**, when *outPut* appears push **ENTER** again.
2. All digits flash for 3 seconds, a green LED labeled "4" illuminates indicating the flashing display is the value at which the meter will produce a 4 mA output. Program desired value per *Five Basic Digit/Display-setting Instructions* on page 17.

#### Setting 20 mA Output Value

1. When **ENTER** is pushed to complete the programming for 4 mA output, the green LED labeled "20" illuminates indicating the flashing display is the value at which the meter will produce a 20 mA output.
2. Program desired value per *Five Basic Digit/Display-setting Instructions* on page 17.
3. An Error message will be displayed if the 4-20 mA output span is smaller than 501 counts.

#### Programming Confirmation

The values that have been programmed to produce the 4 & 20 mA outputs can be quickly checked to make sure they are the desired values. To do this, enter the *outPut* routine by pushing **ENTER** and then pushing **ENTER** again when *outPut* appears.

The green "4" LED illuminates indicating the meter is displaying the value at which it will produce a 4 mA output. Confirm that this is the desired value. Push **ENTER** (within 3 seconds) before the entire display stops flashing and the green "20" LED illuminates indicating the meter is displaying the value at which it will produce a 20 mA output. Confirm that this is the desired value. Push **ENTER** (within 3 seconds) before the entire display stops flashing and the meter returns to indication mode.

## Alarm Programming

### Overview

The meter is equipped with four alarm points as a standard feature. Each alarm may be programmed for either a high or low alarm and for 0-100% deadband. Front panel LEDs indicate alarm status.

Options for two or four relays are available.

To program a high alarm, program the set point above the reset point. To program a low alarm, program the set point below the reset point. To program the alarm deadband, set the reset point above or below the set point by an amount equal to the desired deadband value.

**Example:** Alarm 2 is a high alarm that trips at 1500 and has a deadband of 100. Alarm 2 set point is set at 1500 and its reset point at 1400.

### Setting Alarm Set & Reset Points (RLRR5)

Alarm Set and Reset points are programmed using the *Five Basic Digit/Display-setting Instructions* described on page 17.

1. Push **ENTER** and when *RLRR5* appears, push **ENTER** again. This starts a scan of the four alarm set & reset points. The scan sequence begins with a flashing display of alarm #1 set point. The "1" LED and "S" LED below the display are illuminated to indicate the meter is flashing alarm #1 set point value. Program the desired value for alarm #1 set point using the *Five Basic Digit/Display-setting Instructions* described on page 17.
2. After Alarm #1 set point has been programmed, the meter displays Alarm #1 reset point, as indicated by the "1" LED and "R" LED below the display. Program the desired value for alarm #1 reset point using the *Five Basic Digit/Display-setting Instructions* described on page 17.
3. Program the remaining alarm set and reset points in a similar fashion.
4. When alarm programming is complete the meter will display the process input signal and the front panel LEDs will indicate alarm status.

## Programming Confirmation

To verify that the alarm set and reset points have been programmed as desired, push **ENTER**, and push **ENTER** again when *AL Rr-5* appears. Before the display stops flashing #1 set point value, push **ENTER** again to advance the display to #1 reset point. Continue skipping through the remaining alarm set and reset points. To alter an alarm point value, wait for the first digit to flash and program the desired value using the *Five Basic Digit/Display-setting Instructions* on page 17.

## Alarm Operation

When the meter detects an alarm, a front panel LED illuminates to indicate which alarm point has tripped. In Latching relay mode the LED will stay illuminated until alarm is acknowledged. In automatic relay mode the LED will stay illuminated until the meter display passes through the reset point.

## Set Relays for Fail-Safe Operation

In the fail-safe mode, the relay coils are energized and the Normally Open (NO) contacts are connected to the Common (C) contacts under normal operation. During an alarm condition, the relay coils are *de-energized*, the Normally Closed (NC) contacts are connected to the Common (C) contacts. During a power failure the relay contacts reflect an alarm condition.

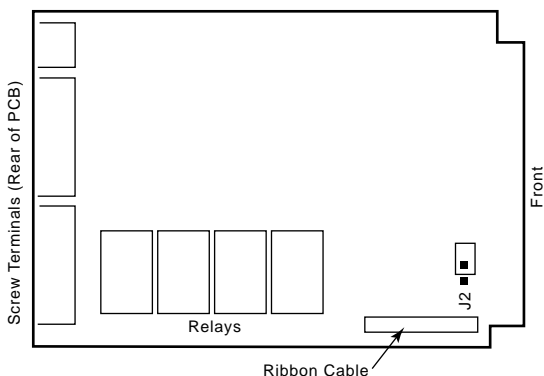

The fail-safe operation can be disabled by removing jumper **J2** located at the front of the relay option card (see figure to left). Refer page 25 for option card installation and removal.

**Figure 10: Option Card Installation**

## Alarm Acknowledgment

The ACK button on the front panel resets the optional relays only and has no effect on the alarm status LEDs.

## Latching (L) or Automatic (R) Relays

The meter is available with 2 or 4 relays. The SPDT relays can be programmed for either manual reset or automatic reset modes.

### Selecting Latching or Automatic Relay Reset

1. Push **ENTER**. When *rELAYS* appears push **ENTER** again.
2. The meter will alternately flash *L* or *R*. Press **ENTER** when desired character is flashing. Meter will then revert back to indication mode.

### Relay Reset Programming

An array of jumpers located behind the front panel on the Display Board is used to program each relay reset mode. Refer to page 25 for front panel removal instructions. The top jumper is used for relay 1, the next for relay 2, etc.

**In Latching Mode** there are 2 ways to reset each relay:

1. Manually at any time. Relay reset jumper **not** installed.
2. Manually only after the input passes the reset point. Relay reset jumper installed.

**In Automatic Mode** there are 2 ways to reset each relay:

1. Automatically when the signal passes through the reset point. Relay reset jumper **not** installed.
2. Automatically + manually. Relay reset jumper installed. That is, a relay may be manually reset prior to the signal passing through the reset point or it will automatically reset when the signal passes through the reset point.

A manual reset will reset all relays that are programmed for automatic + manual reset.

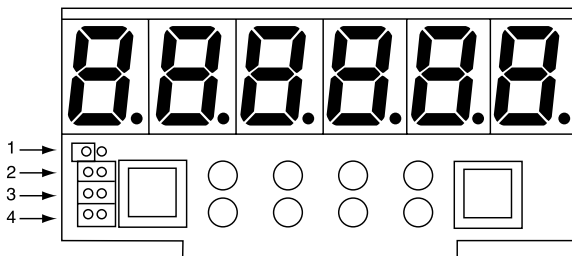

**Figure 11: Relay Reset Jumpers**

An array of jumpers located behind the front panel on the Display PCB is used to program each relay for either automatic or automatic + manual reset. Refer to page 25 for front panel removal instructions. The top jumper is used for relay 1, the next for relay 2, etc. A relay will automatically reset if no jumper is installed. A relay will automatically reset, plus can be manually reset, if a jumper is installed over its respective pins.

**Example Above:** Relay 1 is programmed for automatic reset; Relays 2, 3, & 4 are programmed for automatic + manual reset.

### Lockout Jumper

Once the meter has been completely programmed, a lockout jumper can be installed to restrict further modification to the meter. This jumper is located at the rear of the instrument and is labeled J3. When **ENTER** is pushed with the lockout jumper in place, only *RLPr-5* and *outPut* routines are displayed. These routines may be entered to view their settings, but the settings may not be altered.

## SWITCHING INDUCTIVE LOADS

The meter has the ability to suppress electrical noise generated by switching inductive loads. However, installing Resistor Capacitor (RC) Networks improves this performance and prolongs the life of the meter's relay contacts. This suppression can be obtained with RC networks assembled by the user or purchased as a complete assembly. Refer to the following circuits for RC network assembly and installation:

### AC & DC Loads

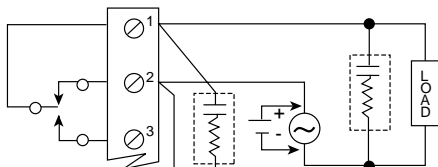

**Figure 12: AC & DC Loads**

### Choose R and C as follows:

R: 0.5 to 1  $\Omega$  for each volt across the contacts

C: 0.5 to 1 microfarad for each 1 A through closed contacts

### Notes:

1. Use capacitors rated for 240 VAC.
2. Snubbers may affect load release time of solenoid loads, check to confirm proper operation.
3. Install the RC network right at the meter's relay screw terminals. An RC network may also be installed across the load.

### Low Voltage DC Loads

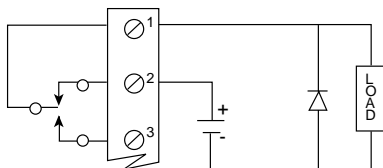

**Figure 13: Low Voltage DC Loads**

Use a diode with a reverse breakdown voltage two to three times the circuit voltage and forward current at least as large as the load current.

### RC Networks Available from Precision Digital

RC Networks are available from Precision Digital and should be applied to each relay contact that switches an inductive load. Part number PDX6901.



## OPTIONS CARD REMOVAL & INSTALLATION

Meter options are installed at the factory. To disable relays' fail-safe operation, it is necessary to remove the PCBs from the case. Refer to the following instructions and illustrations.



***Disconnect power prior to performing the following operations.***

The meter's snap-off cover is held in place by 6 latches that snap into notches on the snap-off cover. To remove the snap-off cover from the meter, grasp it firmly on its top and bottom edges and pull it forward. The latch plate remains around the meter's case.

### **To remove the circuit boards from the case:**

1. Unscrew the retaining screws holding the circuit boards to the case.
2. Remove the screw terminal connectors at the rear of the meter.
3. Push the boards through the case by applying pressure to the circuit boards at the rear of the meter. Apply pressure evenly to both boards.
4. Do not apply pressure to the vertical display board.

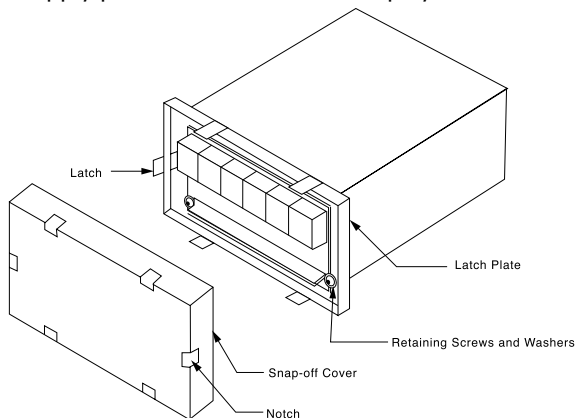

**Figure 15: Front Cover Removal**

5. Configure fail-safe jumper on Options PCB as required. Remove J2 jumper to disable fail-safe operation.
6. To avoid electric shock, re-install the circuit boards in the case prior to applying power.

All programming and calibrating can be performed with the circuit boards installed in the case.

**To re-install the meter in its case:**

1. Fold the Options PCB over the Main PCB, grasp both boards so the Main PCB is on the bottom and the two PCBs are separated by about an inch.
2. Insert the two boards together into the case. Be sure both the top and bottom boards engage the rails, which hold them in place.
3. Do not press on the Display PCB when seating the assembly in the case.
4. Install washers and retaining screws in 4 corners of meter and install front cover.

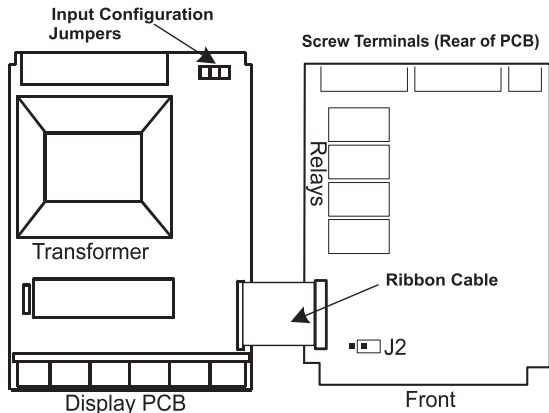
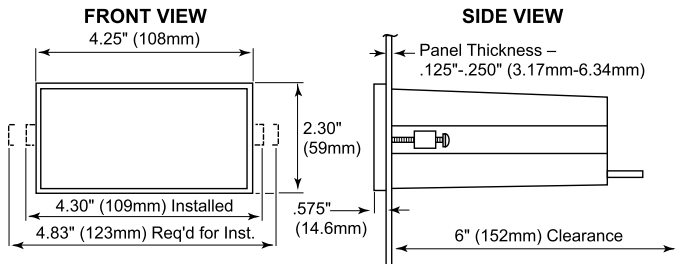
**Figure 16: Option Card Installation****MOUNTING DIMENSIONS****Figure 17: Mounting Dimensions****Notes:**

1. Panel cutout required: 1.772" X 3.622" (45 mm x 92 mm) 1/8 DIN
2. Panel thickness: 0.125" - 0.250" (3.17 mm - 6.34 mm)
3. Clearance: allow 6 inches (152 mm) behind the panel
4. Weight: 16 oz (454 g)

**OTHER PRECISION DIGITAL PRODUCTS**

| <b>Model</b> | <b>Description</b>                                  |
|--------------|---|
| PD118        | MINIMUX® 8-Point Scanner                            |
| PD128        | PLC Annunciator                                     |
| PD141AFO     | VIGILANTE® 4-Point Annunciator with First-out       |
| PD148        | AC/DC Annunciator                                   |
| PD650        | 2.3" LED NEMA 4X Large Display Process Meter        |
| PD655        | 1.0" LED NEMA 4X Large Display Process Meter        |
| PD656        | 0.8" LED Exp-Proof Large Display Process Meter      |
| PD750        | 1/8 DIN Universal Temperature Meter                 |
| PD755        | 1.0" LED NEMA 4X Large Display Temperature Meter    |
| PD756        | 0.8" LED Exp-Proof Large Display Temperature Meter  |
| PD757        | 2.3" LED NEMA 4X Large Display Temperature Meter    |
| PD660        | Low-cost NEMA 4X Loop-powered Meter                 |
| PD661        | Low-cost Exp-proof Loop-powered Meter               |
| PD673/674    | 4½ Digit Loop-powered 1/8 DIN Meter                 |
| PD675/676    | 4½ Digit Loop-powered NEMA 4X Meter (FM Approved)   |
| PD677/678    | 4½ Digit Loop-powered Exp-proof Meter               |
| PD680        | 3½ Digit Loop-powered 1/8 DIN Meter                 |
| PD682        | 3½ Digit Loop-powered 1/8 DIN Meter (FM Approved)   |
| PD686        | 3½ Digit Loop-powered NEMA 4X Meter (FM Approved)   |
| PD687        | 3½ Digit Loop-powered Explosion-proof Meter         |
| PD690        | 1/8 DIN Universal Process Meter                     |
| PD691        | 1/8 DIN Universal mV Strain Gauge & Load Cell Meter |
| PD692        | 1/8 DIN Analog Input Flow Rate/totalizer            |
| PD693        | 1/8 DIN Frequency/Pulse Input Flow Rate/totalizer   |
| PD696        | 1/8 DIN Loop-powered Flow Rate/totalizer            |
| PD697        | NEMA 4X Loop-powered Flow Rate/totalizer            |
| PD698        | Explosion-proof Loop-powered Flow Rate/totalizer    |

# How to Contact Precision Digital

- For Technical Support please  
call: (800) 343-1001  
fax: (508) 655-8990  
e-mail: [support@predig.com](mailto:support@predig.com)
- For Sales Support or to place an order please  
call: (800) 343-1001  
fax: (508) 655-8990  
e-mail: [sales@predig.com](mailto:sales@predig.com)
- For Warranty Registration and to Double Your  
Warranty on-line please visit  
**[www.predig.com](http://www.predig.com)**
- For an online version of this instruction manual  
please visit  
**[www.predig.com](http://www.predig.com)**



## PRECISION DIGITAL CORPORATION

19 Strathmore Road • Natick MA 01760 USA  
Tel (800)-343-1001 • Fax (508)-655-8990

LIM694 Rev B  
03/03